

Jøtul C 350 Winterport  
Fireplace Insert

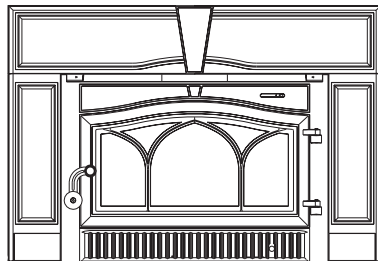

# Jøtul C 350 Winterport Fireplace Insert

Installation and Operating Instructions  
for the United States & Canada



Keep these instructions for future reference.



# Table of Contents

## Standards and Safety Notices

Standards / Codes ..... 4  
Safety Notices ..... 5  
Preparation ..... 5  
**Unpacking the Firebox** ..... 5

## Specifications

C 350 Winterport Fireplace Insert ..... 6

## Installation

Masonry Fireplace Requirements ..... 7  
Factory-built Fireplace Requirements ..... 7  
Chimney Height ..... 7  
Hearth Protection ..... 8  
Clearance to Combustibles ..... 9  
Chimney Connection ..... 10  
Firebox Installation ..... 12  
Surround Assembly ..... 13

## Operation

Wood Fuel ..... 14  
Air Control ..... 14  
Starting / Maintaining the Fire ..... 15  
Formation of Creosote ..... 15  
Blower ..... 16

## Maintenance

Ash Removal ..... 17  
Glass Care ..... 17  
General Maintenance ..... 18  
Gaskets ..... 18

## Illustrated Parts Breakdown

Parts List ..... 20-21  
Miscellaneous Replacement Parts ..... 22

### For Your Records...

Record the following information to help your dealer determine what you will need should your fireplace ever require parts or service. The serial number and manufacturing date are located on the permanent label on the back of the firebox. You may also wish to attach your sales receipt to this manual for future reference.

MODEL: Jøtul C 350 Winterport Fireplace Insert

SERIAL NUMBER:

PURCHASE DATE:

DEALER NAME;

INSTALLED BY:



We recommend that our woodburning hearth products be installed and serviced by professionals who are certified in the U.S. by the National Fireplace Institute® (NFI) as NFI Woodburning Specialists or who are certified in Canada by Wood Energy Technical Training (WETT).



# Installation and Operation Instructions for USA/Canada

## *Installation et fonctionnement pour Canada*

**SAFETY NOTICE: IF THIS SOLID FUEL ROOM HEATER IS NOT PROPERLY INSTALLED, A HOUSE FIRE MAY RESULT. FOR YOUR SAFETY, FOLLOW THE INSTALLATION DIRECTIONS. CONTACT LOCAL BUILDING OR FIRE OFFICIALS ABOUT RESTRICTIONS AND INSTALLATION INSPECTION REQUIREMENTS IN YOUR AREA. SAVE THESE INSTRUCTIONS FOR FUTURE REFERENCE.**

**Avis de sécurité: Une installation non appropriée de ce poêle de chauffage risque de provoquer un incendie. Assurez votre sécurité en respectant les directives d'installation suivantes. Consultez les autorités locales du bâtiment ou de la prévention des incendies au sujet des restrictions et exigences relatives aux inspections d'installations dans votre région.**

*Tested and listed by ITS, Intertek Testing Services, Middleton, Wisconsin.  
Tested to U.S. Standards: ANSI/UL 1482, Canadian Standards: CAN/ULC-S627-M93*



## Standards

The Jøtul C 350 Fireplace Insert has been tested and listed to: U.S: ANSI/UL 1482  
Canada: CAN/ULC-S628-93

*Tests performed by:*  
ITS, Intertek Testing Services, Middleton, WI

*Manufactured and distributed by:*  
Jøtul North America  
55 Hutcherson Dr.  
Gorham, ME 04036

This heater meets the U.S. Environment Protection Agency's emissions limits for wood heaters manufactured and sold after July 1, 1990.

**THE JØTUL C 350 FIREPLACE INSERT IS NOT APPROVED FOR USE IN MOBILE HOMES.**

**THE JØTUL C 350 FIREPLACE INSERT IS ONLY LISTED TO BURN WOOD. DO NOT BURN ANY OTHER FUELS.**

**READ THIS ENTIRE MANUAL BEFORE YOU INSTALL AND USE YOUR NEW FIREPLACE INSERT.**

**SAVE THESE INSTRUCTIONS AND MAKE THEM AVAILABLE TO ANYONE USING OR SERVICING THE FIREPLACE.**

## Check Building Codes

When installing, operating and maintaining your Jøtul C 350 Fireplace Insert, follow the guidelines presented in these instructions, and make them available to anyone using or servicing the stove.

Your city, town, county or province may require a building permit to install a solid fuel burning appliance.

**In the U.S.**, the National Fire Protection Association's Code, NFPA 211, *Standards for Chimneys, Fireplaces, Vents and Solid Fuel Burning Appliances*, or similar regulations, may apply to the installation of a solid fuel burning appliance in your area. For further information on using your heater safely, obtain a copy of the NFPA publication "Using Coal and Wood Stoves Safely," NFPA No. HS-8-1974. The address of NFPA is 470 Atlantic Ave., Boston, MA 02210.

**In Canada**, the guideline is established by the CSA Standard, CAN/CSA-B365-M93, *Installation Code for Solid-Fuel-Burning Appliances and Equipment*.

Always consult your local building inspector or authority having jurisdiction to determine what regulations apply in your area.

## Safety Notices

- **BURN SOLID WOOD FUEL ONLY**
- **DO NOT USE CHEMICALS OR FLUIDS TO START THE FIRE. DO NOT BURN GARBAGE OR FLAMMABLE FLUIDS.**
- **IF THIS ROOM HEATER IS NOT PROPERLY INSTALLED, A HOUSE FIRE MAY RESULT. TO REDUCE THE RISK OF FIRE, FOLLOW THE INSTALLATION INSTRUCTIONS. FAILURE TO FOLLOW THESE INSTRUCTIONS MAY RESULT IN PROPERTY DAMAGE, BODILY INJURY, OR LOSS OF LIFE.**
- **CONTACT THE LOCAL BUILDING OR FIRE OFFICIALS ABOUT RESTRICTIONS AND INSTALLATION INSPECTION REQUIREMENTS IN YOUR AREA. WHEN NOT ADDRESSED IN THIS MANUAL, OR BY LOCAL CODE AUTHORITIES, INSTALLATION SPECIFICATIONS AND REQUIREMENTS DEFER TO NFPA 211 OR CSA B 365**
- **DO NOT CONNECT THIS FIREPLACE TO ANY AIR DISTRIBUTION DUCT OR SYSTEM .**
- **EXTREMELY HOT WHILE IN OPERATION! KEEP CHILDREN, CLOTHING AND FURNITURE AWAY. CONTACT WILL CAUSE SKIN BURNS.**
- **NEVER OPERATE THE FIREPLACE WITH A CRACKED OR BROKEN GLASS PANEL**
- **Install smoke detectors in the living areas and bedrooms of your home. Test them regularly and install new batteries twice annually. When installed in the same room as the stove, a smoke detector should be located as far from the stove as possible to prevent it from sounding when adding fuel to the fire.**
- **Avoid creating a low pressure condition in the room where the stove is operating. Be aware that operation of an exhaust fan or clothes dryer can create a low pressure area and consequently promote flow reversal through the stove and chimney system. The chimney and building, however, always work together as a system - provision of outside air, directly or indirectly to an atmospherically vented appliance will not guarantee proper chimney performance. Consult your local Jøtul authorized dealer regarding specific installation/ performance issues.**

## Installation

### Preparation

We strongly urge you to have your authorized Jøtul dealer install your new Jøtul C 350 Fireplace Insert.

- Check with local building officials to determine what permits may be required before installation.
- Notify your insurance company before installing this fireplace.

### Unpacking the Fireplace

All firebox components of the Jøtul C 350 Fireplace Insert are contained within the carton on a single pallet. The Surround Kit is packaged separately. As you unpack the contents, inspect each item for damage. Notify your dealer of any damage such as dents, cracked glass, or broken bricks.

### Contents:

- Firebox Assembly - including Firebricks
- Steel Riser Bar
- Stove Hardware Bag
  - Fireplace Conversion Notice Plate
  - Leveling Bolts (2)
  - Blower Power Cord
  - AC Power Receptacle Lead
  - Receptacle Inlet Coverplate
  - #8 x 3/4" Phillips screws (2)
  - Firebox Locking Pin

### Tools & Materials Required:

- work gloves
- safety glasses
- tape measure
- phillips screwdriver
- tin snips
- power drill
- High-temperature sealant
- 1" (25 mm) masonry anchors or nails (two)
- 1/4" x 3/4" self-tapping screws (three)
- 10 mm open end wrench or socket

### Removing the Firebox from Pallet

1. Inspect the firebox assembly for damage and contact your dealer if any is found.
2. Remove the two screws that secure the steel Riser Bar assembly to the back of the pallet. See page 8 to determine if Riser Bar is required for your installation.
3. The firebox may be lightened by removing the door, firebricks and baffle plates. See page 18.
4. The firebox is secured to the pallet by a steel bracket on each side and one screw in the bottom at the front. Remove these five screws and lift the firebox to disengage the brackets. Discard brackets.

# Jøtul C 350 Winterport Specifications

## Performance

Fuel: 20" Logs  
 Heat Output<sup>1</sup>: 40,000 BTU/hr. (4.1 kg/hr.)  
 Heating Capacity<sup>2</sup>: Up to 1,300 sq. ft.  
 Overall Efficiency<sup>3</sup>: 71%  
 Emissions: 4.0 grams/hr.  
 Burn Time: Up to 7 hours  
 Dual Blowers: 110 cfm.  
 Shipping Weight: 425 lbs. (193 kg.)

*The Jøtul C 350 Winterport Fireplace Insert meets U.S. EPA emission limits for wood heaters sold after July 1990, and is tested and listed to ANSI/UL 1482, and CAN/ULC S628.93. It is intended for installation in accordance with NFPA 211 or CAN/CSA B365.*

<sup>1</sup> Maximum Heat Output based on total kilograms of dry wood burned in a one hour period. Under specific EPA test conditions, this heater has generated heat output rates ranging from 11,420 to 34,200 BTU's per hour. Heat output in residential installations may vary depending upon site-specific conditions.

<sup>2</sup> Heating Capacity and Maximum Burn Time will vary depending on design of home, climate, wood type and operation.

<sup>3</sup> Overall Efficiency is based on a burn rate of .99 kg wood per hour.

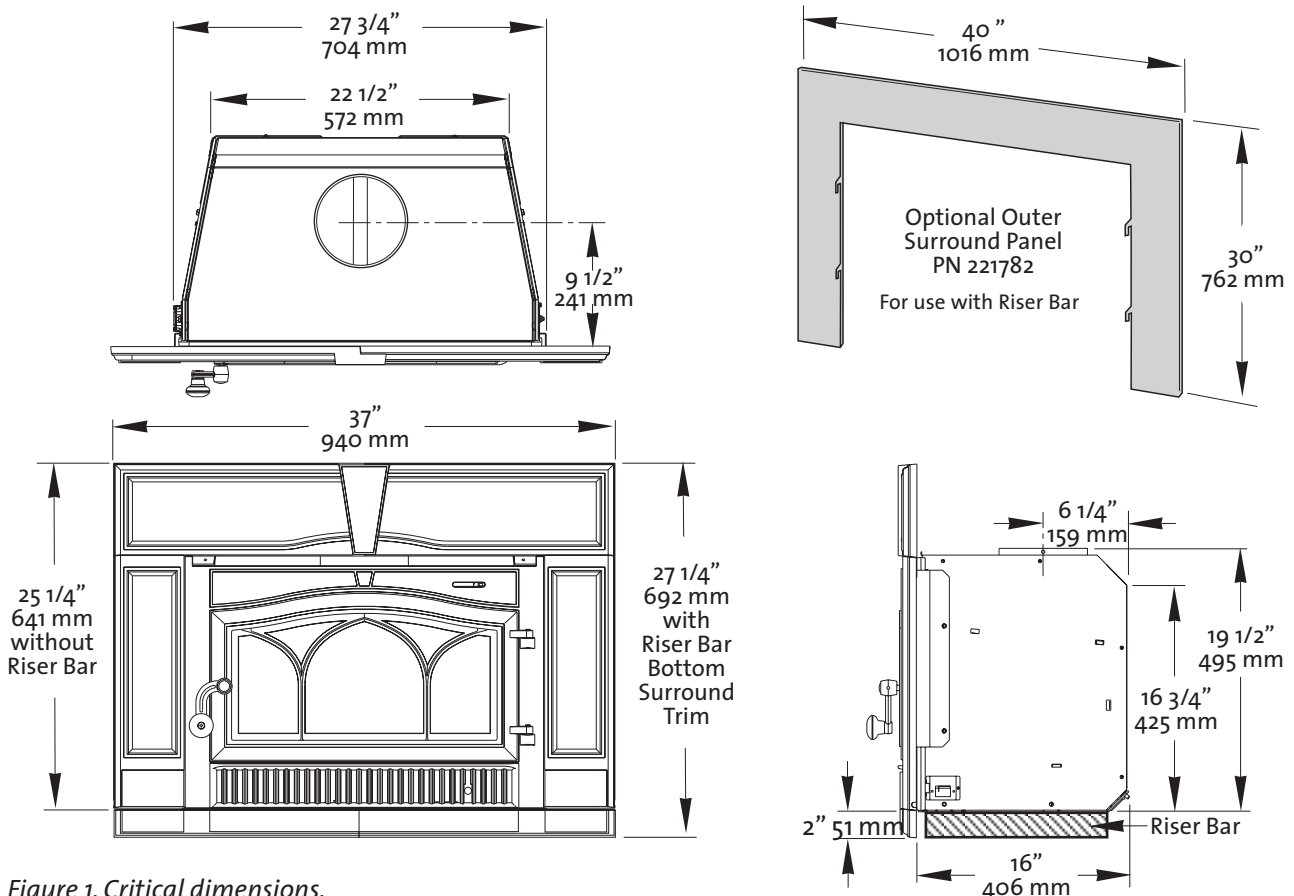

# Installation

## Masonry Fireplace Requirements

- The entire fireplace and chimney must be cleaned and inspected before installation. The system must meet local building code requirements.
- The structure and components must be free of any defects such as cracks or broken bricks or flue tiles. Any damage must be repaired before installation. Any opening that may exist between the masonry of the fireplace and the facing masonry must be permanently sealed.
- The chimney must have a clay tile liner or a stainless steel liner utilizing a positive connection.
- **DO NOT REMOVE BRICKS OR MORTAR FROM THE FIREPLACE OR CHIMNEY STRUCTURE.** However, masonry or steel may be removed from the smoke shelf and adjacent damper frame area to accommodate installation of a chimney liner, provided that their removal will not weaken the structure of the fireplace or chimney, and will not reduce protection for combustible materials.
- **CHIMNEY HEIGHT:**  
Minimum - 15 ft. ( 4.57 meters)  
Maximum - 33 ft. (10.5 meters)

## Minimum Fireplace Dimensions

- A:** FRONT WIDTH \* ..... 32" (813 mm)
- B:** HEIGHT\*\* ..... 19 1/2" (495 mm)
- C:** REAR WIDTH ..... 22 3/4" (577 mm)
- D:** REAR HEIGHT\*\* ..... 16 3/4" (425 mm)
- E:** DEPTH ..... 16" (406 mm)

\* NOTE: Width dimension accommodates clearance for Surround attachment and blower power cord routing.

\*\* Add 2" (51 mm) for use with optional Riser Bar.

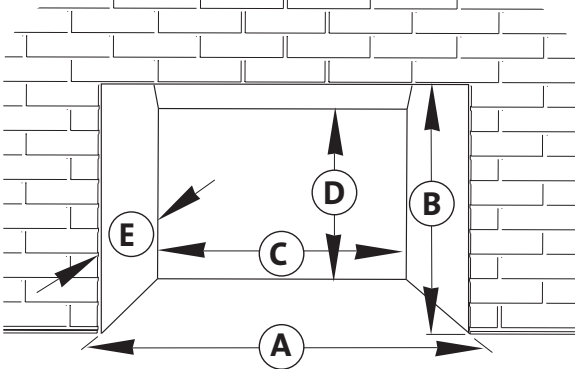

Figure 2. Minimum Fireplace Dimensions

## Factory-Built Fireplace Requirements

The Jøtul C 350 Winterport may be installed into a factory-built fireplace with the following conditions:

- The factory-built fireplace must be listed per UL 127 or ULC S610.
- Installation must include a full height listed chimney liner meeting type HT requirements (2100F) per UL 1777 (U.S.) or ULC S635 (CAN). The liner must be securely attached to the insert flue collar and the chimney top.
- The damper must be sealed to prevent passage of room air into the chimney cavity.
- Circulating air chambers (i.e. in a steel fireplace liner or metal heat circulator) may not be blocked.
- Air flow within and around the fireplace shall not be altered by installation of the insert. The Surround Panels comply with this requirement.
- Alteration of the fireplace is limited to  
a) removal of the damper for liner installation  
b) removal of external, nonfunctional trim which must be stored within the fireplace for replacement.
- Fireplace Conversion Notice PN 220508 must be permanently attached to the back of the fireplace. This metal label is included in the bag containing this manual.
- Final approval is contingent on the authority having local jurisdiction.

## Hearth Protection Requirements

The floor area in front of fireplace insert must be protected from live sparks and radiant heat.

- **Materials:** Hearth protection must be non-combustible insulating board, or the equivalent mortared masonry material. Alternate protection must be composed of materials as specified by NFPA 211.
- **Protected Area:** 16" Deep x 34 1/2" Wide, for both the U.S. and Canada.
  - A) Front** - The protection must extend at least 16 inches (406 mm) forward from the fireplace insert door opening.
  - B) Sides** - Protection must extend 17 1/4 inches (438 mm) to both sides of the centerline of the insert. See fig 5.
- **Flush Hearth:**  
Where the hearth construction is flush with combustible floor materials, the insert must be elevated with use of the 2" Riser Bar supplied. See fig. 3.
- **Raised Hearth:**  
Where the hearth construction is a minimum of 2 1/2" thick, the insert may be installed without use of the Riser Bar. See fig. 4.

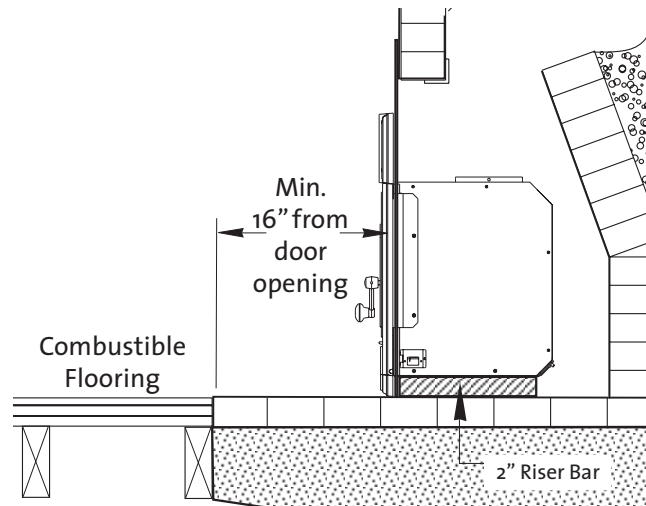

Figure 3. Required hearth protection if flush with combustible floor materials. Riser Bar must be installed.

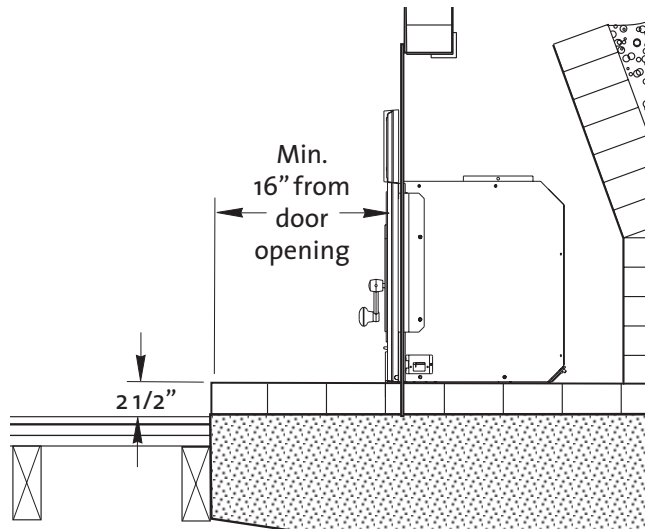

Figure 4. Minimum raised hearth requirement. Riser Bar not required.

## Clearance to Combustible Materials

- There may be no combustible materials located anywhere within 36" (914 mm) of the front of the fireplace insert. This precaution includes items such as drapes or doors that could swing into the area within 36" of the insert.
- Specific clearance (open space) must be maintained between the fireplace insert and combustible materials located above and to the side. See figures 5-6 for minimum dimensions.

## Minimum Clearances

Clearances are measured from the hearth surface, door opening, or centerline as noted below.

**Add two inches to mantel and top trim clearance when Riser Bar is installed.**

- A: Hearth Protection, *width from centerline*: ..... 17 1/4" (438 mm)
- B: Hearth Protection, *forward from door opening*: ..... 16" (406 mm)
- C: To Side Trim, *1" max. thickness, from centerline* ..... 19 1/2" (495 mm)
- D: To Side Room Wall, *from centerline*: ..... 54" (1372 mm)
- E: To Top Trim, *1" max. thickness, from hearth*: ..... 39" (991 mm)
- F: To Mantel, *3" 1/2 max. depth, from hearth*: ..... 48" (1219mm)
- To Mantel, *11 1/2" max. depth*: 54" (1372 mm)

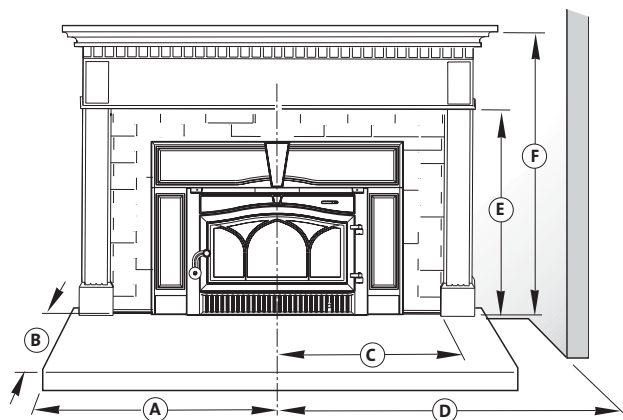

Figure 5. Minimum clearance to combustible materials

## Mantel Clearances

Clearance reduction to mantel construction may be made in conformance to NFPA 211 or CAN/CSA B365.

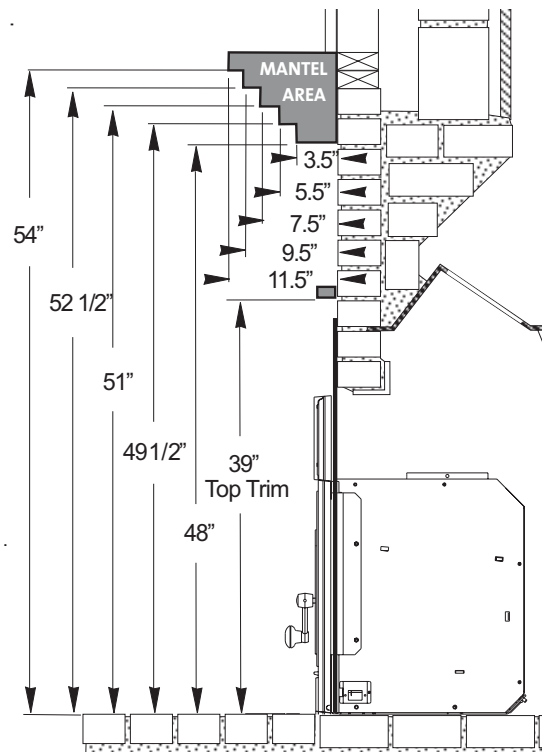

Figure 6. Mantel Clearance Detail - measured from the hearth surface to the lowest mantel surface. Riser Bar is not installed.

**Add two inches to each clearance dimension when Riser Bar is used.**

## Chimney Connection

This insert must be connected to a code-approved masonry chimney or listed factory-built fireplace chimney with a direct (positive) flue connector into the first chimney liner section. The chimney size should not be less than nor more than three times greater than the cross-sectional area of the flue collar.

A positive connection must be made between the fireplace insert and the chimney by one of the following approved methods.

### U.S. Requirement:

The insert is connected to a listed stainless steel flexible connector that extends beyond the chimney flue tile liner. A sealed block-off plate must be installed at the damper area of the existing fireplace. See fig. 7.

For internal chimneys, (no sides of the chimney exposed to the outside below the roofline,) a positive connection to the first flue tile is acceptable provided the tile is no larger than 8" x 12". For external chimneys (one or more sides are exposed to the outside below the roof line, including garages), a positive connection to the first flue tile is acceptable provided the tile is no larger than 8" x 8".

A 6", 7", or 8" stainless steel liner, extending the full height of the chimney, is required for all installations where the flue tile is greater than 8" x 12" for internal chimneys, or 9" x 8" for external chimneys.

### Canada Requirement:

The insert must be installed with a continuous chimney liner of 6" (152 mm) diameter extending from the fireplace insert to the top of the chimney. The chimney liner must conform to the Class 3 requirements of CAN/ULC-S635, Standard for Lining Systems for Existing Masonry or Factory-Built Chimneys and Vents, or CAN/ULC-S640, Standard for Lining Systems for New Masonry Chimneys. See fig. 8.

Do not use aluminum or galvanized steel pipe for chimney connection components - these materials are not suitable for use with solid fuel.

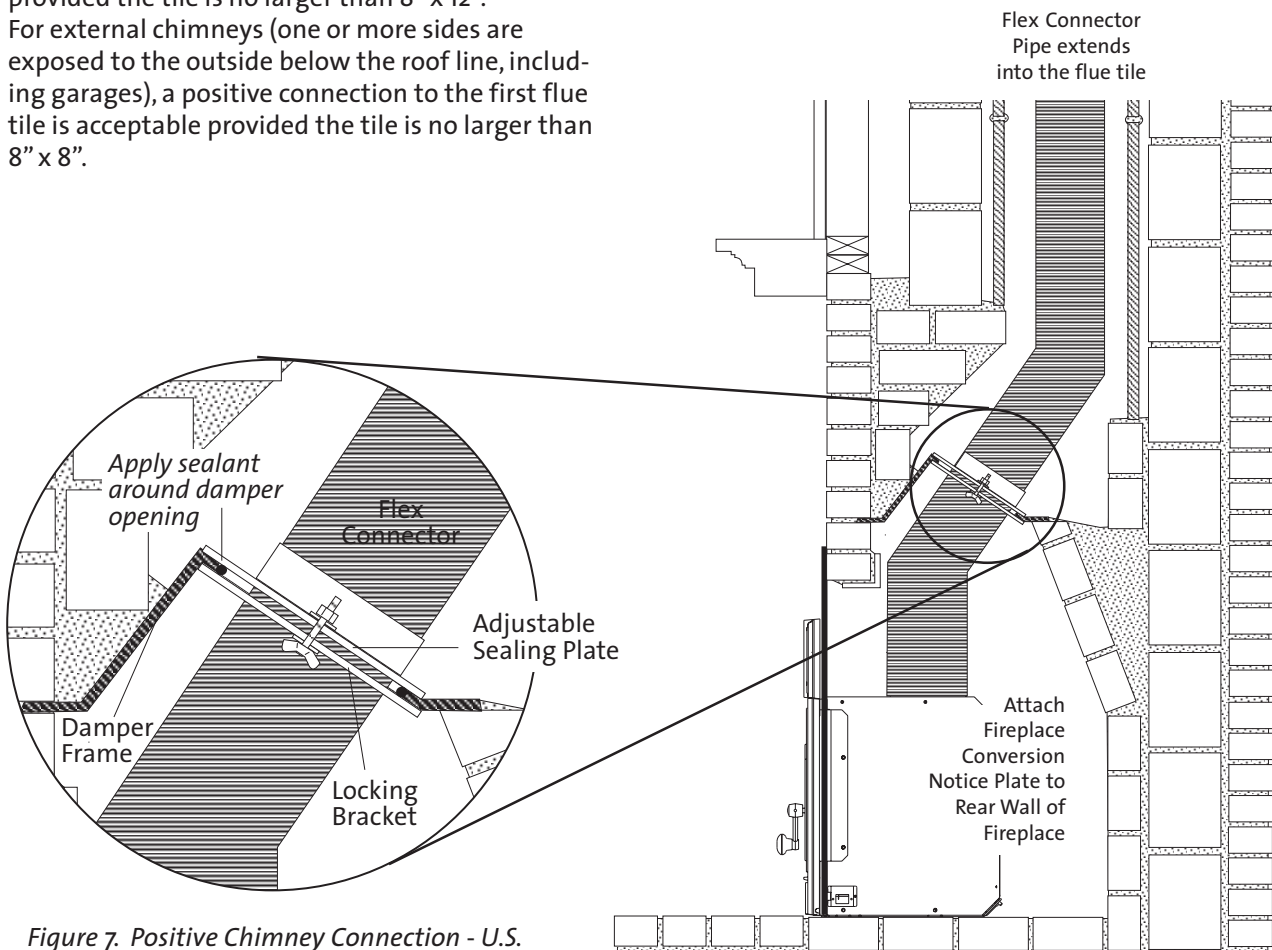

Figure 7. Positive Chimney Connection - U.S.

## Installation

1. Remove the existing damper and linkage components from the fireplace. Alternatively, you can wire the damper plate to lock it in the open position. Thoroughly clean the firebox and smokesheff area with a wire brush.
2. **If the fireplace has been modified to accommodate installation**, use anchors or masonry nails to attach the metal Fireplace Conversion Notice Plate (PN 220508) to the back wall of the masonry fireplace firebox where it will be readily seen should the insert be removed.
3. Install the Flex Connection plate according to the manufacturer's instructions. The sealing plate may require trimming to accommodate your specific fireplace damper.

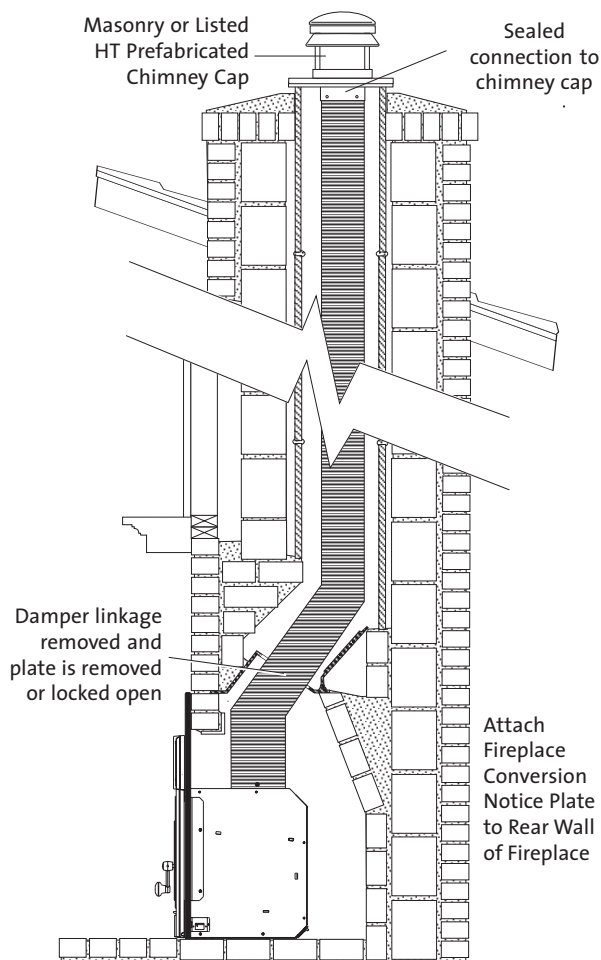

Figure 8. Positive Chimney Connection - Canada.

## Install the Riser Bar

1. If appropriate to your installation (see pg. 8), center the Riser Bar within the masonry fireplace as shown in fig. 9. The forward ends of the Riser Bar should be aligned within 1/2 inch of the fireplace face.
2. Check the level from front to back and side to side. Use the leveling bolts, supplied in the hardware bag, at the rear corners of the Riser Bar to adjust the level as necessary.

## Install the Firebox

1. With the help of an assistant, slide the Firebox into the fireplace cavity. If using a Riser Bar, the Firebox must be engaged with the Riser by means of the Locking Pin included in the hardware bag. Pull the Left Blower forward out of the way to access the Locking Pin hole in the firebox floor. See figs. 8 and 9. When the front edge to the firebox is aligned with the front edge of the Riser, the Locking Pin hole will be aligned with the slot in the top of the Riser Bar crossmember. Insert the Locking Pin and pull the firebox out slightly proud of the fireplace face to facilitate attaching the surround panels. Relocate the blower.

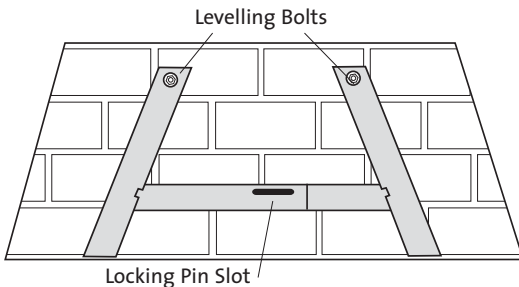

Figure 9. Riser Bar placement.

2. Secure the flue connector to the firebox flue collar using three 1/4" x 3/4" self-tapping screws.
3. Determine to which side the blower power cord will be routed. Insert the AC power receptacle lead through the appropriate inlet in the side of the firebox. See fig. 10. Engage the receptacle bracket with the tab in the inlet opening and secure with one of the #8 x 3/4" phillips screws found in the hardware bag.
4. Plug the male quick-connector on the end of the lead into the corresponding female connector on the blower wire harness.
5. Plug the power cord into the receptacle.
6. Install the inlet coverplate over the inlet opening on the other side of the firebox using the remaining #8 x 3/4" screw.

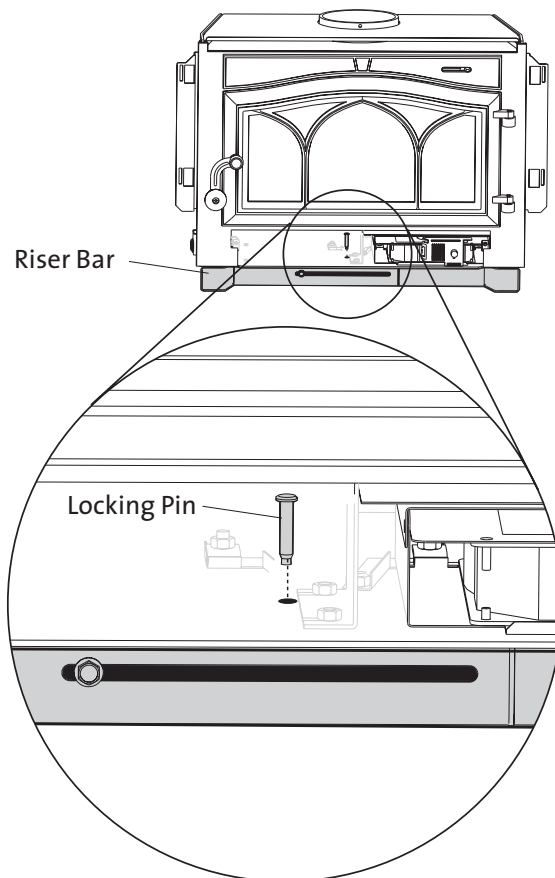

Figure 9. Insert Riser Bar Locking Pin.

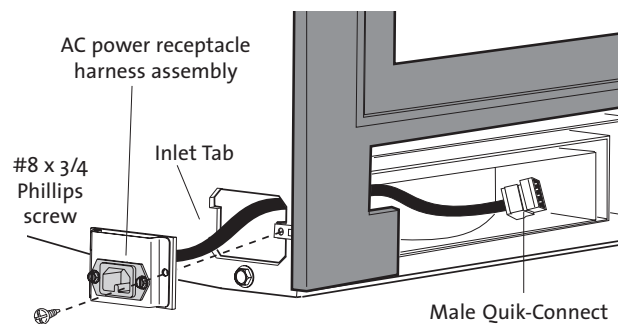

Figure 10. AC power receptacle lead routing.

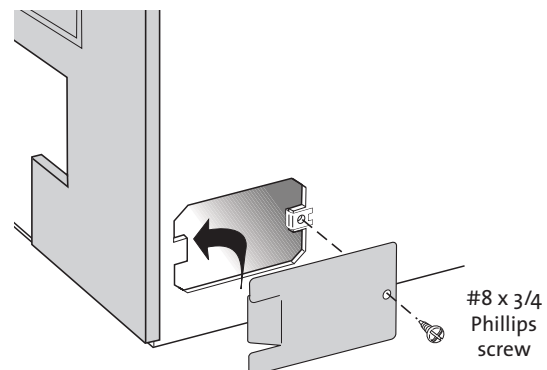

Figure 11. Receptacle Inlet Coverplate installation.

Figure 12.

Surround Panel assembly viewed from backside.

**Tools Required:**

- 10 mm socket or wrench

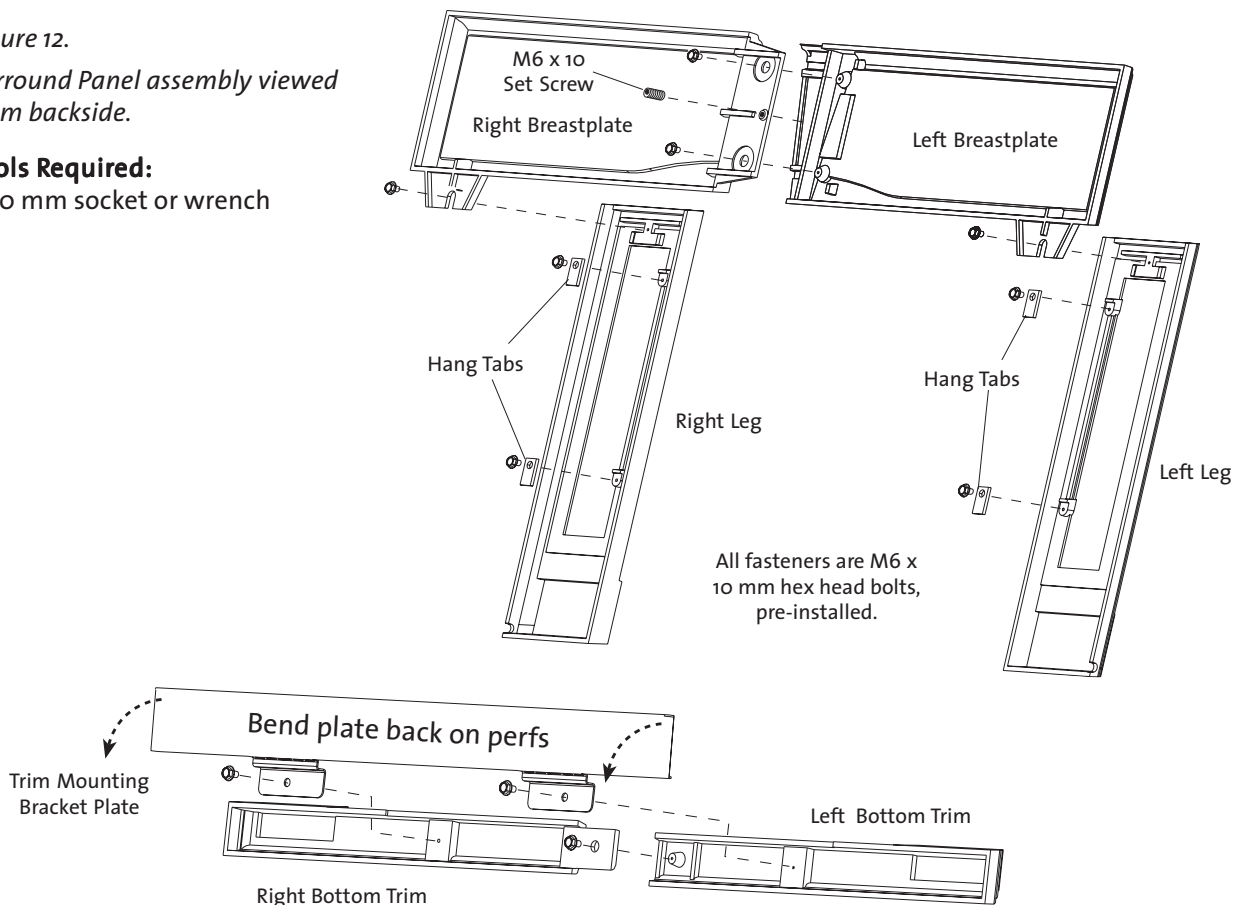

Figure 13. Bottom Surround Trim assembly.

## C 350 Surround Assembly

**All fasteners have already been installed in the appropriate locations at the factory.** You will need to remove them, attach the parts together as described below and reinstall the fasteners at those locations.

- 1. Layout the parts.** Place the castings face down on a protective surface such as carpeting, blankets or a sheet of cardboard.
- 2. Attach the Breastplates to each other.** Use a 10 mm socket or wrench with two M6 x 10 hex head flange bolts. Adjust the set screw to obtain parallel alignment of the two plates.
- 3. Attach the Leg plates.** *The Legs must be oriented with the Hang Tabs on the inside edges as shown in fig. 12.* Use the two remaining M6 x 12 hex head flange bolts to attach the Legs to the Breastplate assembly.
- 4. If the Riser Bar is used,** attach the two Bottom Surround Trim panels together with the single M6 x 10 hex bolt. Attach the Trim Mounting Bracket to the back of the Bottom Trim assembly using the other two M6 x 10 bolts. **Be sure to orient the bracket as shown in fig. 13.**

Tighten just snug enough to allow for final adjustment when the Surround assembly is attached to the firebox.

Bend the perforated mounting plate down 90° as shown in Fig 13. Insert and center the bracket plate sandwiched between the firebox and the Riser Bar.

- 5. If appropriate, attach the Extended Surround Panel** to the firebox. With the painted side facing out, engage the hooked tabs on panel with the slots in the backside of the Surround Brackets on the firebox. Extend the blower power cord out beyond the surround panel.
- 6. Attach the Assembly to the Firebox.** Lift the entire assembly upright and position it in front of the insert firebox. The four Hang Tabs on the surround legs must engage with the adjacent cutouts in the two brackets on either side of the firebox opening. The surround will easily engage with these brackets if the firebox is slightly proud of the fireplace opening.

Hang the surround assembly on the firebox and push the entire unit into position so that the surround is flush against the fireplace face.

# Operation

Read the following section carefully before building a fire in your Jøtul C350 Fireplace Insert.

## Fuel

This stove is designed to burn natural wood ONLY. Wood that has been air-dried for a period of 6 to 14 months will provide the cleanest most efficient heat. **Frequent use of green or inadequately seasoned wood is conducive to creosote accumulation and generally poor performance.**

### DO NOT BURN...

- Coal
- Treated or painted wood
- Garbage
- Chemical Chimney cleaners
- Cardboard
- Colored paper
- Solvents
- Any synthetic fuel or logs

The burning of any of these materials can result in the release of toxic fumes. **NEVER USE GASOLINE, GASOLINE-TYPE LANTERN FUEL, KEROSENE, CHARCOAL LIGHTER FLUID, OR SIMILAR LIQUIDS TO START OR "FRESHEN-UP" THE FIRE. Always keep such liquids away from the heater at all times.**

WARNING

NEVER ALLOW THE FIRE TO REST DIRECTLY ON THE GLASS. THE LOGS SHOULD ALWAYS BE SPACED AT LEAST ONE INCH FROM THE GLASS TO ALLOW FOR PROPER AIR FLOW WITHIN THE STOVE.

## Air Control Settings

A single lever regulates the Primary Air flow that controls the intensity of the fire and consequent heat output and burn time. This lever is located within the slot on the upper right front of the fireplace insert.

When first starting or reviving the fire, the control lever should be set at the far right position to allow the maximum amount of air into the stove. See fig.14. After the fire is well-established, the lever should be set at position to moderate incoming air to maintain the desired long term heat output and/or burn time.

In general, the more air made available to the fuel will result in the hottest fire intensity and the fastest fuel consumption. Alternatively, the less air made available to the firebox will result in low heat output and slow fuel consumption.

WARNING:

OPERATE THIS FIREPLACE INSERT ONLY WITH THE FRONT DOORS FULLY CLOSED. PARTIALLY OPENED DOORS MAY RESULT IN OVERFIRING. ALSO, IF DOORS ARE LEFT PARTLY OPEN, GAS AND FLAME MAY BE DRAWN OUT OF THE STOVE OPENING, CREATING RISKS FROM BOTH FIRE AND SMOKE.

## Blower Settings / Air Control

Use the following guide to establish optimal performance from the C 350.

Burn Rate	Air Control Setting	Blower Speed
Low	1/8" Open	Low / On at 30 min.
Med. Low	3/16" Open	Low / On at 30 min.
Med. High	1/4" Open	Low / On at 30 min.
High	Max. Open	High / On

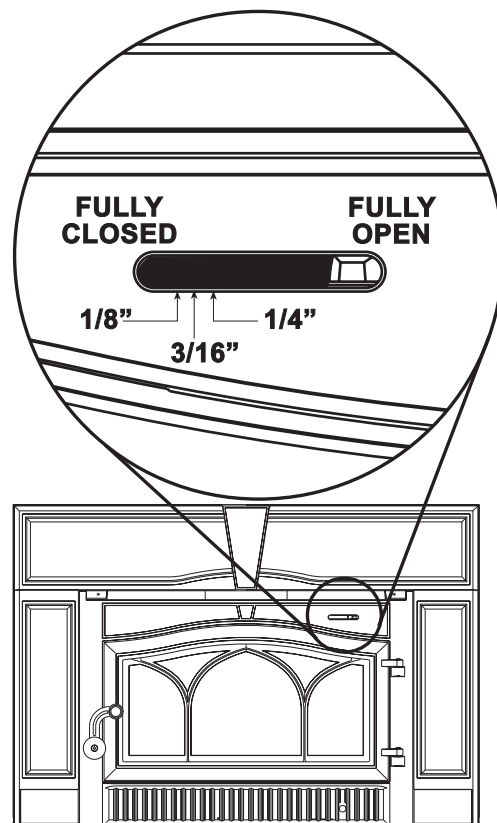

**Blower Speed Control**

Figure 14. Air Control Setting

## Starting and Maintaining a Fire

**Burn only solid wood directly on the bottom grate of the stove, do not elevate the fire in any way.**

1. Set the Air Control Lever in the full open position. 2. Crumple several sheets of newspaper directly on the grate.
2. Place several pieces of small dry kindling (approx. 1" in diameter) on top of the newspaper, with two to three small logs (approx. 2" to 3" in diameter) on top.
3. Light the fire and close the door. Gradually build the fire by adding larger and larger logs as the fire develops a bed of coals.
4. When you have added the final logs, adjust the Air Control Lever to provide the desired fire intensity.

Experiment with a variety of air control settings to determine the best one for your individual circumstances. Remember that fuel characteristics, chimney system condition, building design, and weather conditions all affect the performance of your fireplace insert. In time, you will discover how these elements combine and how you can work with them to achieve satisfactory performance.

**NEVER OVERFIRE THE STOVE. IF ANY PART OF THE STOVE OR CHIMNEY GLOWS, YOU ARE OVERFIRING. A HOUSE FIRE OR SERIOUS DAMAGE TO THE STOVE OR CHIMNEY COULD RESULT. IF THIS CONDITION OCCURS, IMMEDIATELY CLOSE THE AIR CONTROL.**

## Adding Fuel to the Fire

When reloading the stove while a bed of hot embers still exists, follow this reloading procedure:

- Always wear stove gloves when tending to the fire.
- Push the Air Control Lever to the full open position (far right).
- Wait a few seconds before opening the door. This allows the renewed air circulation to clear unburned gases from the firebox.
- Use a stove tool or poker to distribute the hot embers equally around the firebox.
- Load the fuel, usually with smaller logs first.
- Close the doors and secure the latch.

- Wait 5 – 10 minutes for the fire to re-establish before adjusting the Air Control Lever for the desired heat output. If a thick bed of live coals is present, you may be able to add fuel and immediately set the air control without waiting for the fire to be re-established.

## Creosote Formation

The Jøtul C 350 WINTERPORT is designed to burn wood cleanly and efficiently when operated as described in this manual. However, when wood is burned slowly and at low temperatures, tar and other organic vapors are produced which condense on the relatively cooler chimney flue surfaces to form creosote. Failure to keep the chimney system free of creosote build up could result in a chimney fire.

The creosote that accumulates in the chimney is highly flammable and is the **fuel** of chimney fires. To prevent chimney fires, it is important to have the chimney flue and connector pipe inspected at least twice annually and cleaned whenever accumulation of 1/4" or more is evident. A qualified chimney sweep or other authorized service person can provide this service.

It is also important to remember that chimney size, temperature and height all affect draft which in turn affects the formation of creosote. An exterior chimney, whether masonry or prefabricated steel, will be exposed to cold outside temperatures, and consequently, will be more prone to creosote accumulation than an interior flue.

A chimney flue located within the home interior will benefit from the insulating characteristics of the building itself. Consequently, the flue system will be less conducive to condensation of unburned gases and minimal creosote accumulation will result.

As a general rule, try to avoid burning the insert at the lowest air control settings. Although a low setting will prolong burn time, it may also result in incomplete combustion. In reducing the fire intensity, draft is weakened and the chimney flue cools. This, together with the increase in unburned gases, leads to rapid creosote accumulation.

## Break-in Period Ventilation

It is normal for a new stove to emit odor and possibly smoke during the first few fires. This is characteristic of the burn-off of residues from the manufacturing process and the curing of painted surfaces. Open a window near the fireplace insert to provide plenty of fresh air to the room during this "seasoning" period.

## Blower Operation

Access the blower control panel by lifting the cast iron lower grille up off the insert.

The dual blowers will enhance heat circulation around the firebox and out into the room. The blowers operate together, controlled by a heat activated switch (snapstat) that will ONLY function when the control switch is in either the Manual or Automatic setting and the speed control is ON. After the fire has been burning for a time, the snapstat will react to the heat and activate the blower, if the switch is in the Automatic position. Conversely, the blower will continue to operate until the snapstat cools as the fire wanes. The blower will then shut off automatically.

For best performance, do not turn the switch on until after the fire is well-established.

If the blower is not needed, place the blower control switch in the OFF position.

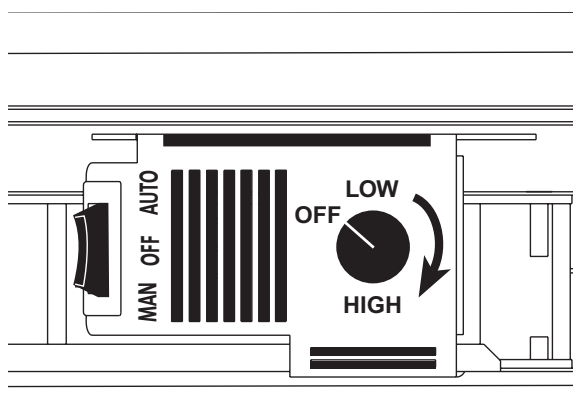

Figure 15. Blower and speed controls.

- THIS BLOWER MUST BE ELECTRICALLY GROUNDED IN ACCORDANCE WITH LOCAL CODES OR, IN THE ABSENCE OF LOCAL CODES, WITH THE CURRENT ANSI/ NFPA 70, NATIONAL ELECTRICAL CODE OR CSA C22.1-CANADIAN ELECTRICAL CODE.
- THIS UNIT IS SUPPLIED WITH A THREE-PRONG (GROUNDING) PLUG FOR PROTECTION AGAINST SHOCK HAZARD AND SHOULD BE PLUGGED DIRECTLY INTO A PROPERLY GROUNDED THREE-PRONG RECEPTACLE. DO NOT CUT OR REMOVE THE GROUNDING PRONG FROM THE PLUG.
- ALWAYS DISCONNECT THE POWER SUPPLY WHEN PERFORMING ANY SERVICE ON THE FIREPLACE INSERT.

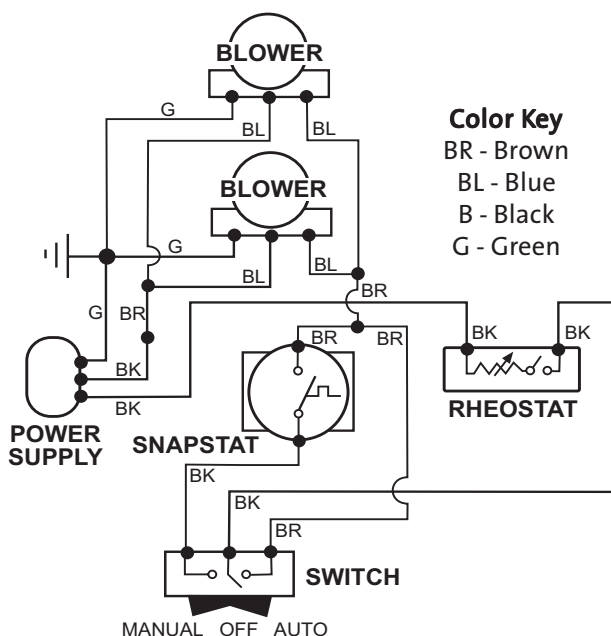

Figure 16. C 350 Wiring diagram.

# Maintenance

## Ash Removal

Always wear stove gloves when handling ashes.

Ash removal will be required periodically depending on how frequently the stove is used. Use a steel ash shovel and metal container with a tight-fitting lid.

**NEVER USE A PAPER OR PLASTIC BAG AS AN ASH RECEPTACLE.**

The container of ashes should be placed on a noncombustible floor or on the ground, well away from all combustible materials, pending final disposal. If the ashes are disposed of by burial in soil or otherwise dispersed, **they should be kept in the closed container until all coals and cinders have thoroughly cooled.**

## Glass Care

### Cleaning

Occasionally it will be necessary to clean the carbon deposits and fly ash off of the glass. If deposits are allowed to remain on the glass for an extended period of time, the glass may become etched and cloudy.

Creosote deposits should burn off during the next hot fire.

1. The glass must be **COMPLETELY COOL**.
2. Only use a cleaner that is specifically designed for this purpose. **DO NOT USE ABRASIVE CLEANING AGENTS.** The use of abrasives will damage the glass, leaving a frosted surface. Crumpled newspaper is an especially good cleaning material.
3. Rinse and dry glass completely before lighting a fire.

## Glass Replacement

Always operate the doors slowly and cautiously to avoid cracking or breaking the glass. Never use the door to push wood into the firebox. If the glass becomes cracked or broken follow the replacement procedure below.

### IMPORTANT:

REPLACE GLASS ONLY WITH JØTUL CERAMIC GLASS PART #156069 SPECIFICALLY DESIGNED FOR THE JØTUL C 350 WINTERPORT FIREPLACE INSERT. DO NOT USE SUBSTITUTES. REPLACEMENT GLASS PANELS CAN BE ORDERED THROUGH YOUR JØTUL DEALER.

NEVER OPERATE THE STOVE WITH A CRACKED OR BROKEN GLASS PANEL.

1. Remove the door from the stove and place on a flat surface.
2. First loosen and then carefully remove all of the glass clips from the inside of the door. See fig. 17.
3. Remove all pieces of the glass panel and gasketing.
4. Remove all remaining debris from the glass area using a wire brush.
5. Apply a small bead of gasket/stove cement and the new gasket. Do not overlap the ends of the gasket rope.
6. ***Orient the glass with the IR Coating Label facing out.*** Center the new glass panel over the gasket and loosely reinstall the glass clips. Tighten the clips, alternating at opposite corners. Avoid applying uneven pressure on the glass. Remove the IR Coating Label.
7. It may be necessary to retighten the glass clips after the stove has burned and the gasketing has seated.

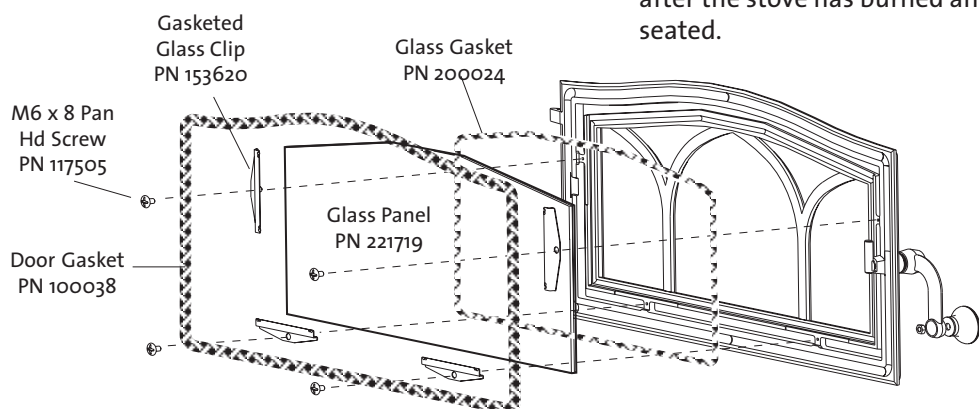

Figure 17. Replacing the door glass and gaskets.

## General Maintenance

Regular maintenance will assure proper performance and prolong the life of your Jøtul C350. The following procedures do not take long and are generally inexpensive. When done consistently, they will help increase the life of your fireplace insert and assure satisfactory performance.

- Thoroughly clean the insert. Enamel surfaces should be cleaned with soap and water.
- Empty firebox of all soot and ashes. Never use a household vacuum cleaner to remove ashes. Only a shop vac with a metal container is acceptable and only when you are certain the ashes are cold.
- Inspect the firebox using a utility light inside and out for cracks or leaks. Replace all cracked bricks and repair leaks with furnace cement.

## Removing the Insert for Cleaning

### U.S. Direct-connection Only:

1. Disconnect the blower power cord from its outlet.
2. Open the firebox door and pull the insert out enough to disengage the surround panel assemblies by lifting up off of the brackets.
3. Remove the three screws that attach the flue connector to the flue collar, and disengage the it from the insert.
5. Pull the firebox and cabinet forward as a unit. The flue connector, liner, and chimney can now be inspected and cleaned.
6. See the Installation section of this manual for reassembly procedures.

### Canada Installations (Full Reline):

The chimney can be swept directly into a bucket placed under the flue outlet, with removal of the two cast iron baffle plates.

1. Push up on the Left Baffle to disengage its locating boss from the Secondary Air Tube.
2. Slide the Secondary Air Tube to one side to disengage it from the opposite side Air Channel and remove it from the firebox.
3. Lift the Right Baffle up and forward off of the rear and side support shelves.
4. Repeat with the Left Baffle.
5. Re-assemble in the reverse order, being sure to engage the nub on the Left Baffle with the hole in the Secondary Air Tube.

## Gaskets

Check door and glass gaskets for seal integrity. The gaskets should be soft enough to be somewhat resilient to the touch. Over time, gaskets will compress and harden. Replace worn-out or hardened gaskets with the appropriate size material available from your local Authorized Jøtul Dealer.

To check the seal of the front doors, close and latch the doors on a dollar bill and slowly try to pull the dollar bill free. The seal is too loose if the bill can be easily removed. Adjust the door latch and test again.

## Gasket Replacement

See the Parts List on page 21 to order the correct gasket material. See also fig. 18.

1. Remove the old gasket material with a pliers and thoroughly clean the channel with a wire brush.
2. Lay out the new gasket around the channel to determine length. Trim the gasket to leave 1" excess.
2. Apply a small bead of furnace cement in the channel.
3. Lightly press the new gasket into the channel, being careful to avoid compressing or stretching it. Trim the gasket further as necessary to allow the tail end to slightly overlap the other end.
4. Wait ten minutes to allow the cement to set and then close and latch the doors. Reopen the doors and, using a damp cloth, wipe away any excess cement that may be squeezed out from under the gasket.

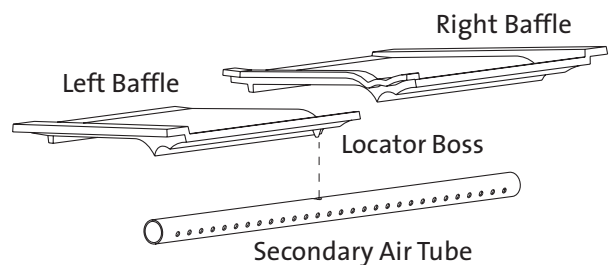

Figure 18. Baffle plate assembly.



Use only genuine Jøtul replacement parts.  
 Do not substitute parts from any other manufacturer.  
 See your local Authorized Jøtul Dealer or contact us  
 directly:

**Jøtul North America**  
**55 Hutcherson Dr.**  
**Gorham, Maine 04038**

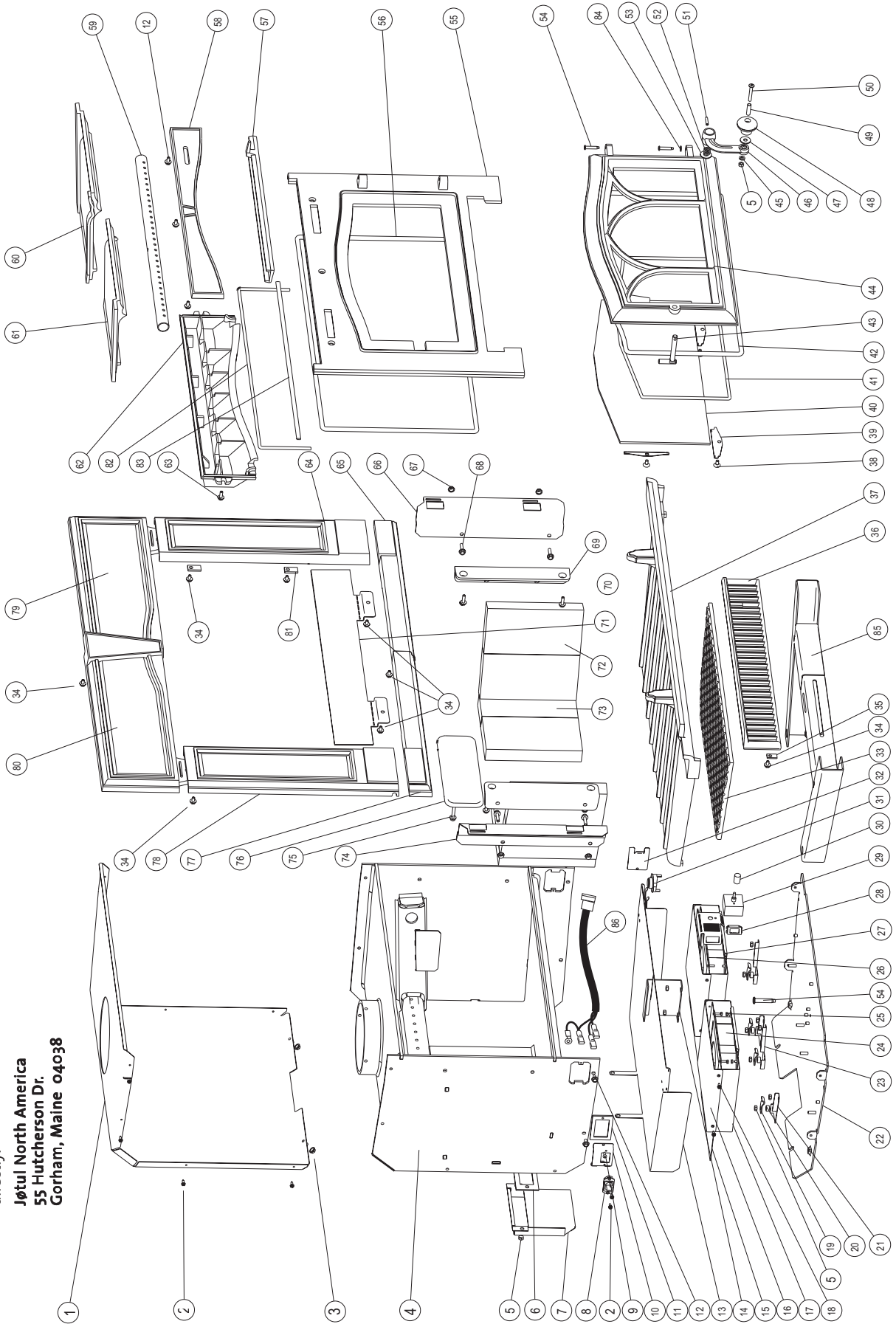

Figure 19. Jøtul C 350 Illustrated Parts Diagram

## Jøtul C 350 Winterport Parts List

No.	Description	PartNumber
1.	Rear Shroud	220904
2.	Screw, #8 x 1/2" Hex Slit	117917
3.	Nut, M6 Flange	117968
4.	Firebox Assembly	220909
5.	Nut, M6 Hex	9930
6.	Gasket, Secondary Air Channel	221750
7.	Secondary Air Channel	221721
8.	AC Power Receptacle	221790
9.	Screw, M4 x 8 Pan Head	117921
10.	Receptacle Mounting Plate	221798
11.	Receptacle Mounting Plate Gasket	221799
12.	Bolt, M6 x 12 Hex Head Flange	117130
13.	Blower Shield Assembly	221959
14.	Firebox Support	221759
15.	Blower Intake Shroud	221762
16.	Blower Top Shroud	221761
17.	Blower Base Shroud	221760
18.	Screw, #8 x 1/2" Slit	117917
19.	Blower Attachment Clip	121041
20.	Spacer, .250 x .500	117994
21.	Guide, Left Blower	221764
22.	Shroud Assembly, Base	220905
23.	Guide, Right Blower	221763
24.	Left Blower Assembly	156047
25.	Nut, M4 Hex	117922
26.	Right Blower Assembly	156048
27.	Right Blower Base Assembly	221965
28.	Rocker Switch	220708
29.	Rheostat, Solid-state Variable	221787
30.	Rheostat Control Knob	221788
31.	Snap-stat	220755
32.	Receptacle Cover Plate	221967
33.	Insulating Panel, Grate	221784
34.	Bolt, M6 x 10 Hex Head Flange	9962
35.	Hang Tab	129680
36.	Control Door, Matte Black Paint	10427692
	Control Door, Blue Black Enamel	156070
	Control Door, Jøtul Iron Paint	10427685
37.	Grate Plate	10427716
38.	Screw, M6 x 8 Pan Head	117505
39.	Glass Clip	153620
40.	Glass Panel, Ceramic IR Coated	156069
41.	Rope Gasket, Fiberglass - LD .250	200024
42.	Rope Gasket, Fiberglass - LD .360	100038
43.	Door Latch Bolt	221720
44.	Door, Matte Black Paint	156066
	Door, Blue Black Enamel	156067
	Door, Jøtul Iron Paint	156068
45.	Washer	110904
46.	Cast Door Handle	103712
47.	Insulating Washer	124853
48.	Wooden Door Knob	126244
49.	Door Handle Sleeve	126229
50.	Bolt, M6 x 40 PHP	117796
51.	Roll Pin, 5 mm x 24 mm	117733

No.	Description	Part Number
52.	Door Handle Compression Spring	126124
53.	Washer, Door Handle	117587
54.	Hinge Pin	127075
55.	Front Plate, Matte Black Paint	10427592
	Front Plate, Blue Black Enamel	10427527
	Front Plate, Jøtul Iron Paint	10427585
56.	Rope Gasket, Fiberglass LD .360	100038
57.	Air Slider, Cast Iron	10428216
58.	Air Cover Plate, Matte Black Paint	10429792
	Air Cover Plate, Blue Black Enamel	156059
	Air Cover Plate, Jøtul Iron Paint	10429785
59.	Secondary Air Tube	221753
60.	Baffle Plate, Right	10429616
61.	Baffle Plate, Left	10429516
62.	Airwash Manifold	10427816
63.	Bolt, M6 x 16 Flange Head	99625
64.	Surround Leg, Right - Matte Black Paint	10427392
	Surround Leg, Right - Blue Black Enamel	156063
	Surround leg, Right - Jøtul Iron Paint	10427385
65.	Trim, Bottom Right - Matte Black Paint	10430192
	Trim, Bottom Right - Blue Black Enamel	156065
	Trim, Bottom Right - Jøtul Iron Paint	10430185
66.	Surround Support, Right	221733
67.	Nut, M6 Flange	117968
68.	Bolt, M6 x 25 Flange Hex	118019
69.	Cast Attachment Plate	10429916
70.	Bolt, M6 x 20 Hex Head	117117
71.	Bracket, Bottom Trim	221770
72.	Brick, 4.5 x 8.5 - Refractory	221751
73.	Brick, 3.5 x 8.5 - Refractory	221752
74.	Surround Support, Left	221732
75.	Bolt, M6 x 40 Hex Head	117990
76.	Brick Retainer, Cast	10430016
77.	Trim, Bottom Left - Matte Black Paint	10429892
	Trim, Bottom Left - Blue Black Enamel	156064
	Trim, Bottom Left - Jøtul Iron Paint	10429885
78.	Surround Leg, Left - Matte Black Paint	10427292
	Surround Leg, Left - Blue Black Enamel	156062
	Surround Leg, Left - Jøtul Iron Paint	10427285
79.	Surround Panel, Breastplate, Right - Matte Black	10427192
	Surround Panel, Breastplate, Right - Blue Black	156071
	Surround Panel, Breastplate, Right - Jøtul Iron	10427185
80.	Surround Panel, Breastplate, Left - Matte Black	10427092
	Surround Panel, Breastplate, Left - Blue Black	156061
	Surround Panel, Breastplate, Left - Jøtul Iron	10427085
81.	Hang Tab	128401
82.	Rope Gasket, Fiberglass - LD .250 SA	129644
83.	Gasket, Flat - .125 x 8 mm	127215
84.	Washer, .062 x .500	117947
85.	Riser Bar Assembly	221988
86.	AC Harness w/ Receptacle, Replacement	156057
87.	Set Screw, M6 x 10 mm - Surround adjustment	04-117720

## Jøtul C 350 Winterport Options

Extended Surround Panel, Matte Black Paint	156055
Extended Surround Panel, Jøtul Iron Paint	156056

## Cast Iron Assembly Replacement Parts

<b>Description</b>	<b>PartNumber</b>
Front Door Assembly, Complete	
inc. castings, handle and gaskets	
Matte Black Paint	156066
Blue Black Enamel	156067
Jøtul Iron Paint	156068
Front Plate Assembly w/ gasket	
Jøtul Iron Paint	10427585
Matte Black Paint	10427592
Blue Black Enamel	156058



Cat.no 138376  
Jøtul North America September 2006

This appliance must be installed in conformance with local and national building regulations. It is important that these instructions be carefully read and understood before beginning the installation. Jøtul pursues a policy of continual product development. Consequently, products may differ in specification, color or type of accessories from those illustrated or described in various publications.

Jøtul vise sans cesse à améliorer ses produits. C'est pourquoi, il se réserve le droit de modifier les spécifications, couleurs et équipement sans avis préalable.



**Jøtul North America Inc.**

55 Hutcherson Dr.  
Gorham, Maine 04038  
USA

**Jøtul ASA**

P.O. Box 1411  
N-1602 Fredrikstad,  
Norway